

Grimm | **AUDIO**

***AD1* manual**

Please read this manual before operating the unit!

Table of Contents

| | |
|---------------------------------|----|
| Important Safety Instructions | 5 |
| 1. Installing | 7 |
| 2. Signal connections | 8 |
| 3. About DSD | 10 |
| 4. Specifications | 13 |
| 5. Grimm Audio Limited Warranty | 15 |

Introduction

Thank you for choosing the Grimm Audio AD1 DSD AD converter for your production. This product embodies our company philosophy of providing the most transparent and direct signal chain possible, enabling you to achieve the best possible results sonically and artistically.

This manual describes how to set up the unit in your studio as well as important tips on how to get the best performance from the AD1. In addition, some background information on the unit's operation is provided.

We have taken pains to insure that the manual is up to date and clear. Should you have any further questions or suggestions on how to improve this manual, please feel welcome to get in touch with us.

We hope this investment will bring you many years of creative enjoyment and help you achieve your goals.

Important Safety Instructions

Grimm Audio gaat er van uit dat u deze Engelstalige tekst volledig begrijpt. Als u hier moeite mee heeft dient u contact op te nemen met Grimm Audio. Op verzoek sturen wij u een vertaling toe.

Grimm Audio nimmt an, dass Sie diesen Englischen Text völlig verstehen. Wenn notwendig, nehmen Sie bitte Kontakt auf mit Grimm Audio. Auf Wunsch wird Ihnen eine Übersetzung zugeschickt.

Grimm Audio suppose que le lecteur comprend parfaitement le texte en Anglais ci-dessous. En cas de doute s.v.p. contacter Grimm Audio. Si nécessaire, on pourra vous envoyer une traduction.

Grimm Audio da por supuesto que el texto en versión Inglesa no ofrece ninguna duda de interpretación y se entiende íntegramente. Si este no fuese su caso rogamos contacte con Grimm Audio quien, a petición, se encargaría de enviarle la correspondiente traducción.

Please follow these precautions when using this product:

1. Read these instructions.
2. Keep these instructions.
3. Heed all warnings.
4. Follow all instructions.
5. Dangerous voltage is inside this apparatus. Opening is only allowed by qualified service personnel.
6. Verify line voltage before use.
7. Do not defeat the safety purpose of the polarized or grounding-type plug. A polarized plug has two blades with one wider than the other. A grounding-type plug has two blades and a third grounding prong. The wide blade or the third prong are provided for your safety. When the provided plug does not fit into your outlet, consult an electrician for replacement of the obsolete outlet.
8. Protect the power cord from being walked on or pinched, particularly at plugs, convenience receptacles, and the point where they exit from the apparatus.
9. Unplug this apparatus during lightning storms or when unused for long periods of time.

10. Do not use this apparatus near water.
11. Do not use this apparatus outside.
12. Do not expose the apparatus to dripping or splashing. Do not place objects filled with liquids (flower vases, drink cans, coffee cups, etc) on the apparatus.
13. Clean only with a dry, soft, non-fluffy cloth. Do not spray any liquid cleaner onto the cabinet, as this may lead to dangerous shocks. Do not spray any liquid cleaner onto the faceplate, as this may damage the front panel.
14. Install in accordance with the manufacturer's instructions.
15. Do not install near any heat sources such as radiators, heat registers, stoves, or other apparatus (including amplifiers) that produce heat. Avoid exposure to direct sunlight.
16. Use only attachments or accessories specified by the manufacturer.
17. Use only with a cart, stand, bracket, or table designed for use with professional audio or music equipment. In any installation, make sure that injury or damage will not result from cables pulling on the apparatus and its mounting. If a cart is used, use precaution when moving the cart/apparatus combination to avoid injury from tip-over.
18. This unit runs warm when operated normally. Operate in a well ventilated area with at least six inches of clearance from peripheral equipment. If this product will be installed in a rack, make certain there is sufficient air movement within the rack. Do not place the unit directly on a carpeted surface.
19. This product, in combination with an amplifier and headphones or speakers, may be capable of producing sound levels that could cause permanent hearing loss. Do not operate for a long period of time at a high volume level or at a level that is uncomfortable. If you experience any hearing loss or ringing in the ears, you should consult an audiologist.
20. Refer all servicing to qualified service personnel. Servicing is required when the apparatus has been damaged in any way, such as when the power-supply cord or plug is damaged, liquid has been spilled or objects have fallen into the apparatus, the apparatus has been exposed to rain or moisture, does not operate normally, or has been dropped.
21. **WARNING:** To reduce the risk of fire or electric shock, do not expose this apparatus to rain or moisture.

1. Installing

Unpacking and Inspection

Your AD1 was carefully packed at the factory and the carton it came in was designed to protect it from the trials and tribulations of shipping. Keep the box and all packing materials, so that in the unlikely event that you need to return the AD1 for servicing, you can do so safely.

Mounting the AD1

The AD1 can mount in any standard 19" rack. Make sure you leave at least 1U of space above and below the AD1, and more if the adjacent equipment runs warm. The AD1 does not produce RF fields nor is susceptible to them. You can position it near other digital gear such as computer and disk recorders without worry. In general it is a good idea to keep some distance between monitors (LCD and CRT) and audio cables because of risk of low level noise due to stray magnetic fields.

Grimm Audio products have a real wood face plate that provides a beautiful and vivid appearance. To maintain the outstanding looks, one is advised to take some precautions:

- Do not place the AD1 in humid nor very dry environments. The wood might crack.
- Do not use chemical or alcohol based cleaner on the wood.

AC Power Hookup

The AD1 has a linear power supply that needs to be factory set for your local line voltage. Make sure to check the noted line voltage on the back below the IEC cable entrance ('wired for ... V') and verify that this complies with your locally supplied line voltage. Grimm Audio cannot be responsible for problems caused by using the AD1 with improper AC wiring or voltage. Since the AD1 does not have a power switch on the front panel, a convenient way to power down the unit is to use a power strip equipped with a switch.

2. Signal connections

The AD1 is build as a modular system. A chassis can hold both AD and DA boards. This manual will focus on description of the AD boards. If your unit is equipped with DA channels, please refer to the DA1 manual that came with your unit.

An AD board offers an analog input on XLR and a DSD format digital output on BNC, which can be found right above the XLR of the same channel. Although we strongly advise using balanced connections throughout your whole system, the analog input is designed such that it will perform equally well on unbalanced audio as on balanced audio. Please pay attention to a proper wiring of unbalanced cables. In the cable at the source side pin 3 should be connected with pin 1, as can be seen in the illustration. Unbalanced equipment sporting XLR outputs are normally already wired in this manner.

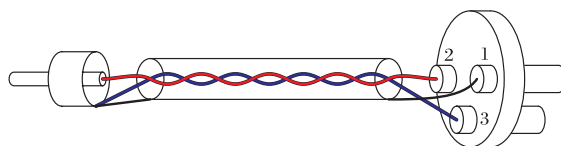

Input sensitivity

Your AD1 is calibrated for a 0 DSD level of $+18 \text{ dBu} \pm 0.1 \text{ dB}$. This equals 14 dB of headroom above a 0 VU defined as $+4 \text{ dBu}$, which is common in mastering. Due to choices made with the ultimate sound quality in mind, this level is factory installed and cannot be calibrated. If you ordered your AD1 to be calibrated to another level, it will be indicated on the case.

DSD does not have a defined clipping level like PCM. 0dB DSD is defined as 50% modulation index (100% modulation index means a constant '1' or '0' output signal. Hence, 50% modulation means a maximum of 75% or a minimum of 25% of output samples are '1'). In practice the performance of all 1 bit sigma delta modulators deteriorates very quickly with signals above 0 DSD. One problem is that the high frequency noise increases severely. The standard for SACD production, 'Scarlet Book', demands for a maximum HF noise. The AD1 will conform to Scarlet Book with signals up to $+1.8 \text{ dB DSD}$. Nevertheless we strongly discourage you to drive the AD1 that hard. First, performance of any DSD AD deteriorates above 0 DSD. Secondly, the Scarlet book recommends equating 0dB DSD with 0dBFS when deriving the CD layer on a hybrid disc. This means that levels above 0 DSD will be clipped on the CD layer. Finally, DA chips in many SACD players do not have any headroom above 0dB DSD and will clip severely when addressed with signals above 0 DSD. In chapter 'About DSD' on page 10 you will find more information about this subject.

Clock

On the back of the unit there are two BNC connectors for synchronising the AD1. Most DSD equipment requires a word clock connection, apart from the SDIF3 data lines. The upper BNC is a word clock output, the lower one a word clock input. Both operate at the DSD basic word clock rate of 44.1 kHz. Next to the word clock input you'll find three switches that relate to the operation mode of the AD1. The upper switch selects master mode or slave mode. In slave mode the lower switch selects what kind of jitter attenuation is used on the incoming word clock. 'Ultra' has a jitter suppression down to 0.1 Hz, 'Tight' to about a few Hz. Since more jitter attenuation is better, Ultra mode is the preferred choice. Because of fundamental issues however, latency between the incoming word clock and reclocked output word clock (and data) can become larger than 20 ns when the incoming jitter is very large. In Tight mode it will never exceed 20 ns. Sony's SDIF3 specification demands that the timing of word clock and data is within 20 ns. Many recorders are more tolerant than this, so Ultra mode will work 95% of the time. If you encounter data sync problems in slave mode however, you should switch to Tight mode. In that case, please check your master clock as well, because its jitter apparently is very high.

The best method is to slave the recorder not to the house sync but to the word clock output of the AD1. The AD1's clock output and data output are always sync within 3ns. Some recorders will correctly sync to the embedded clock in the SDIF3 data stream, obviating the need for an explicit word clock connection. Consult the manual of your recorder for this function.

In slave mode, the white "slave" LED indicates lock. When the unit is locked, the LED will be continuously on. When the unit is unlocked and while it is acquiring lock, the LED will blink. Allow several tens of seconds after engaging slave mode for the circuitry to settle.

The input impedance of the Word Clock input BNC is factory set to 'High impedance'. The reason will be explained in the next paragraph. Because of this an external 75 Ohm terminator on a T-bar is needed. On demand an internal jumper can be set to 75 Ohm.

Use of more AD1's in parallel

To facilitate recording more than 8 channels simultaneously, several AD1's can be synced. In this situation perfect data sync is needed, which means all slaving AD1's need to be set to 'Tight' mode. The word clock inputs of these AD1's are all connected to the word clock output of the first unit, using T-bars on every unit and terminating with a 75 Ohm terminator on the last one. In this setup the SDIF3 outputs of all AD1's are sync within 20 ns.

3. About DSD

DSD is another word for 1-bit PCM sampled at 2.8224MHz. As a release format, SACD is the only one actually using this 1-bit data, but as an internal processing format it's surprisingly common. The vast majority of audio converters operate at 1 (or a few bits) at megahertz sampling rates. That means the audio in normal CD production started its life in a DSD-like format. To get to PCM, digital low-pass filtering and decimation is required. This is mostly invisible to the user because converter ICs contain the decimation filter on-board, and put out PCM. But even if you're not aware of it, your PCM converter has quite a bit of DSD-like processing going on inside. Alternatively the decimation can also be done externally in the Grimm Audio DD1 or a DAW equipped with DSD inputs. Doing so has the benefit of better control over conversion quality. The filters in converter IC's aren't optimised for sound quality but are designed for minimum latency and processing power.

The AD1 runs at the DSD rate of '64 fs' (2.8224MHz), which seems like old technology in the light of 128 or 256 fs competitors. The higher rate formats however were designed to get around technical issues related to signal processing in DAW's, not to solve sonic issues in converters. The quality of the signal is ultimately limited by the analogue performance of the converter used, not by the data format. Grimm Audio strives to attain the best audio performance possible. The primary recipe is to keep the signal path simple, resulting in a discrete-circuit continuous time architecture. This design was shown to deliver its best at 1 bit and 2.8224MHz sampling rate. A substantially higher sampling rate would introduce settling time problems, resulting in noise modulation artefacts. More bits would introduce linearity problems and yet another breed of modulation artefacts. This strategy has paid off in unprecedented measured and sonic performance. For SACD mastering DSD is the format of choice by default. And if your product will be released on CD (with 22 kHz brickwall filtering) the supposed benefit of lower HF noise by using a higher sample rate is entirely lost while the performance loss inside the 20kHz range, incurred by optimising for out-band noise, is maintained.

While DSD is the format of choice for high quality recording and SACD mastering, digital editing is performed with PCM audio. This because every change that's made to the DSD audio stream will lead to a wider word length than 1 bit. Since a multibit signal at 2.8224 MHz has a data rate that's too high for practical use, DSD is converted to a lower rate PCM format before editing. When Philips engineers were building DSD editing tools the design criterion was thus to find a PCM format that would not detract from the sonic capabilities of DSD. It was found that it was possible to convert a DSD signal to 352.8kHz/32 bit and back without incurring any audible quality loss, as long as good care was taken with the filtering and remodulation stages. Later on this format was called 'DXD'. Conversion of DSD to DXD is performed 'on the fly' in certain DAW's.

One could ask if it makes sense to record DSD format audio, when it will be edited in PCM anyway. The answer depends on how your recording and editing sessions are structured. Certainly for recordings made on stand-alone recorders, the use of DSD as a storage format is warranted. Practice so far shows that DSD is at least as sonically transparent as 192kHz/24 bit and better than 96kHz/24bit. However, one channel of DSD takes up only 2.8Mbit/s, whereas one channel of 192kHz/24bit takes up 4.6Mbit/s. Given that the AD1 puts out DSD data anyway, it's most economical to store the audio in this format. Converting to PCM during recording would only increase the data rate without any added benefit. The conversion to PCM is best left to the Grimm Audio DD1 or the DAW when the recording is loaded.

When mastering an SACD, the final stage is a 1-bit noise shaper. Some people worry over running a signal through a noise shaper twice. There are certainly problems (accumulation of HF noise) to be expected from applying several stages of deltasigma modulation to an audio signal. Twice is not a problem, five or six times is another matter. This means that using a deltasigma A/D in the front and a final digital remodulator at the back is not going to cause any trouble. This is especially so considering the particular choice of modulator used in the AD1. For one, as a continuous-time design it outputs slightly different data compared to a digital modulator, meaning you're not stacking two identical processes. For another, its outband noise characteristic is about the most gentle one found in DSD converters anywhere, largely owing to the lack of coefficient rounding. The HF noise floor of the digital remodulator is therefore always going to dominate the end result.

DSD maximum levels and HF noise

A topic that has caused quite a bit of confusion is the max level of a DSD stream. The absolute signal level of a DSD signal is expressed as modulation index. A 100% modulation index means all output samples are "1", -100% means all output samples are "0". When no signal is present, modulation index is 0% so on average half of the output samples are "1", the other half "0". Practical analogue 1-bit modulators produce negligible distortion when used below 50% peak modulation index. It is therefore common practice to design the decimation filters in 1-bit based PCM converters to output 0dBFS when the modulation index of the 1-bit modulator output is 50%. This practice has become enshrined in the Scarlet Book standard, where the 0dB reference level for DSD signals has been set to 50% peak modulation index. The standard strongly recommends that the CD layer of hybrid discs be derived from the 2-channel SACD layer with 0dBFS = 0dBDS. All SACD players are designed such that the signal levels in DSD and PCM modes match when this convention is followed.

This does not mean, however, that the deltasigma modulator in DSD A/D converters falls apart above 50% modulation index, far from it. The AD1, for instance will provide acceptable performance for signal levels up to +1.8dBDS. Above this level, modulator overload occurs. Using this margin to boost one's loudness level

by 1.8dB is not a good idea though. In order to get the best commercial SNR spec, the D/A converters in most CD/DVD/SACD players max out at 0dBFS and hence 0dBDS. Feeding them DSD signals modulated above 0dBDS will cause analogue overload in the filters, digital overload in the preprocessing or both. Therefore, playing the Loudness Race game by modulating above 0dBDS is liable to result in unplayable discs.

The level confusion is further compounded by the peak level spec set forth in the Scarlet Book. The Scarlet Book spec defines maximum allowable peak modulation in terms of a running flat average of DSD data bits. A pressing plant will refuse an SACD master if out of any consecutive 28 samples more than 24 or less than 4 are "1". In modulation index terms this corresponds to $\pm 71.4\%$ or $+3.10\text{dBDS}$. In keeping with the Scarlet Book standard, DSD DAWs sport a peak reading meter based on a 28-sample average. This has led to the belief that an SACD can be made to play 3.1dB louder than a CD. This is quite incorrect, because a 28-sample un-weighted average is a very shoddy low-pass filter and includes a very large amount of shaped HF noise from the modulation process. A typical 1-bit modulator will produce a "+3.1dB" reading on a 28-sample averaged level meter when the input level is around +1.5dB. By the same token, maximum modulation level specs given by several converter manufacturers are also misleading, because they state the 28-sample average reading at the 1-bit output, not the corresponding input level.

A problem related with HF noise is encountered when mixing tracks, recorded in DSD. Some people found there was hardly any HF headroom. Watching the HF meters in their DAW showed various amounts of noise when comparing AD converters but no AD provided low enough HF noise to facilitate normal mixing. Indeed there is quite some variation in the amount of HF noise put out by DSD A/D converters. Most converters use a front-end running at a different sample rate or word length and use a digital modulator to convert this to a signal compatible with the DSD spec. Quite often these digital modulators are designed for the lowest possible noise floor. Tested using a digitally generated signals, better than -130dB in-band noise is common. This is quite suboptimal because only the signal-to-noise ratio of the analogue front-end needs to be accommodated, while the improved "virtual" noise level comes at the expense of greatly increased HF noise levels. A similar effect is encountered in the 1-bit remodulation stages in DSD DAWs.

The main reason for the mixing problem however is not all DSD DAWs use the best processing filters. During the development of DXD for editing of DSD signals, much effort went into designing filters with optimum cut-off and slope that were demonstrably transparent in listening tests while providing enough HF attenuation to deliver precisely the processing margin required by practical processing needs.

If you find your DSD production system does not have the headroom needed for mixing large numbers of channels with substantial gain, this may be an indication of the DAW and/or the ADC not implementing the best possible filters and remodulation stages. A Grimm Audio DD1 format converter will solve this issue.

4. Specifications

Discretely build continuous-time 6th order sigma delta modulator running at 64 x 44,1 kHz or 2.822 MS/s (DSD). As shown in the block diagram, only four resistors separate the audio signal from the feedback DAC. Everything else is within the feedback loop.

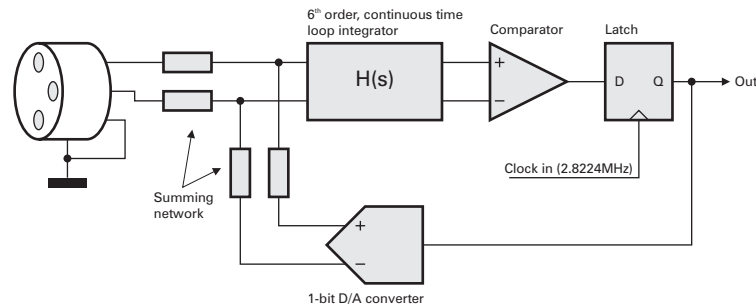

The clock PLL is a hybrid analog / digital design, based on a custom ultra-low jitter crystal oscillator. It features a ‘tight’ mode with attenuated jitter rejection at low frequencies to comply to the SDIF3 standard when necessary.

The power supply has CLC filtering after rectification to provide a relatively clean DC voltage for internal distribution. Each channel has local shunt regulators featuring 120 dB power supply rejection and a high impedance supply path. Thus all variations in load current are kept local to the circuit. The power buss and ground carry only DC current.

Specifications

Frequency response ± 3 dB: 0 Hz – 55 kHz.

THD at full signal: -127 dB (both balanced and unbalanced).

Noise (20 kHz bandwidth): -116 dB.

Idle mode HF noise: 9 dB below Scarlet Book appendix E&F.

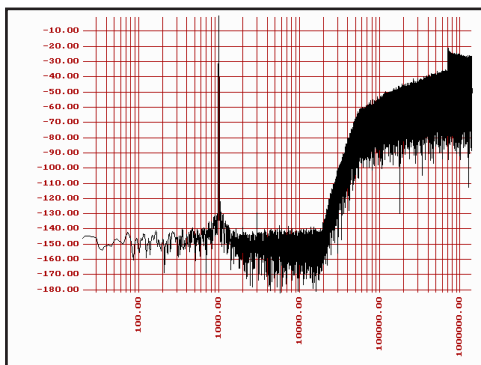

Output spectrum with full scale input.

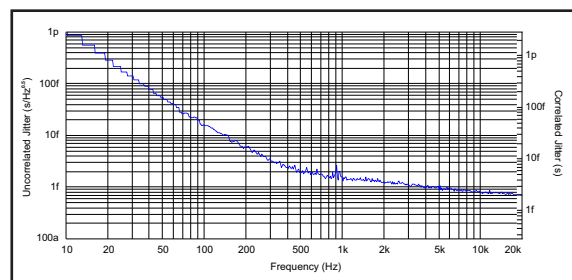

Jitter spectrum at converter stage.

Input sensitivity: 18 dBu for 0 DSD. Equal performance on balanced and unbalanced sources.

Input impedance: 10 kOhm balanced, 5 kOhm unbalanced.

Data outputs SDIF3 compliant.

Output impedance = 60 Ohm.

Word clock input Z_{in} = internally selectable HiZ or 75 Ohm (default HiZ).

Word clock input threshold for '1' level > 0.5 Vpp.

Word clock output Z_{out} = 75 Ohm.

Latency word clock out – data out: 3 ns.

Latency word clock in – word clock out, Tight mode: max ± 20 ns depending on input clock jitter. Ultra mode adjusted to less than 50 ns, but may be larger due to input clock jitter.

Internal intrinsic clock jitter 2,1 ps RMS (above 10 Hz) at converter stage.

PLL performance (slave mode):

Ultra mode 90 dB attenuation @ 10 Hz, improving at 60 dB/dec above that.

Tight mode 36 dB attenuation @ 100 Hz, improving at 60 dB/dec above that.

Maximum ambient temperature for operation: 40 degrees Celsius.

The unit shall be mounted in a 19" rack keeping at least 1U empty space above and below.

Life expectancy power supply electrolytics > 45.000 hours if case is installed according to our requirements

Weight: 15 kg

Dimensions: 440 x 388 x 85 mm.

Power consumption 8 channel box: 100 W.

Wood type of front: Mahogany.

Grimm Audio contact information

Grimm Audio CV

Kanaaldijk-Zuid 11

5611 VA Eindhoven

The Netherlands

+31 (0)40-213 0186

Email: info@grimmaudio.com

Website: <http://www.grimmaudio.com>

5. Grimm Audio Limited Warranty

Grimm Audio CV ("Grimm Audio") warrants this product to be free of defects in material and workmanship for a period of one (1) year for parts and for a period of one (1) year for labor from the date of original purchase. This warranty is enforceable only by the original retail purchaser and cannot be transferred or assigned.

During the warranty period Grimm Audio shall, at its sole and absolute option, either repair or replace free of charge any product that proves to be defective on inspection by Grimm Audio or its authorized service representative. In all cases disputes concerning this warranty shall be resolved as prescribed by law. To obtain warranty service, the purchaser must first call or write Grimm Audio at the address and telephone number printed below to obtain instructions where to send the unit for service. All enquiries must be accompanied by a description of the problem. All authorized returns must be sent to Grimm Audio or an authorized Grimm Audio repair facility postage prepaid, insured and properly packaged. Proof of purchase must be presented in the form of a bill of sale or some other positive proof that the product is within the warranty period. Grimm Audio reserves the right to update any unit returned for repair. Grimm Audio reserves the right to change or improve design of the product at any time without prior notice.

This warranty does not cover claims for damage due to abuse, neglect, alteration or attempted repair by unauthorized personnel, and is limited to failures arising during normal use that are due to defects in material or workmanship in the product.

In no event will Grimm Audio be liable for incidental, consequential, indirect or other damages resulting from the breach of any express or implied warranty, including, among other things, damage to property, damage based on inconvenience or on loss of use of the product, and, to the extent permitted by law, damages for personal injury.

© 2006, Grimm Audio CV. All rights reserved
Reproduction in whole or in part is prohibited.
Specifications subject to change without notice.

AD1man01, 2/15/06

