

Grimm | **AUDIO**

CCI manual



Please read this manual before operating the unit!

TPinLB

Table of Contents

Introduction	4
Important Safety Instructions	5
1. Installing	7
2. Signal Connections	8
3. Operation	8
4. Setting up the Studio	12
5. Pro Tools	16
6. Jitter and PLL's explained	18
7. Specifications	23
8. Grimm Audio Limited Warranty	25

Introduction

Thank you for choosing the Grimm Audio CC1 Central Clock distributor for your production environment. This product features a rich set of distributor functions, based upon an ultra low jitter clock oscillator. It embodies our company philosophy of providing the most transparent signal chain possible, enabling you to achieve the best possible results sonically and artistically. Large parts of the CC1 circuitry, like the oscillator and its power supplies, use a discrete design. Because of this a CC1 has more than 700 components. During construction 125 separate elements are tested.

The CC1 can be used in a wide variety of applications such as:

- House Sync generation in audio and/or video studios. Sixteen outputs permit the use of the reliable “star” distribution scheme. The extremely low jitter of the CC1 clock outputs maximises the sound quality potential of the attached devices. In case you need to slave your system to video clock, please insert a Grimm Audio VCC, ‘video to word clock converter’ before the clock input.
- Clock stability improvement, and hence improved sound, of digital live desks and digital snakes.
- Clock distribution in broadcast studios.
- Improvement of your home audio system. For instance in conjunction with word clock equipped devices or as reclock unit in between a transport or media system and a DA converter.

This manual describes how to set up the unit in your studio, live or home environment as well as important tips on how to get the best performance from the CC1. In addition, some background information on the unit’s operation is provided.

We hope this investment will bring you many years of creative enjoyment and help you achieve your goals.

Important Safety Instructions

Grimm Audio gaat er van uit dat u deze Engelstalige tekst volledig begrijpt. Als u hier moeite mee heeft dient u contact op te nemen met Grimm Audio. Op verzoek sturen wij u een vertaling toe.

Grimm Audio nimmt an, dass Sie diesen Englischen Text völlig verstehen. Wenn notwendig, nehmen Sie bitte Kontakt auf mit Grimm Audio. Auf Wunsch wird Ihnen eine Übersetzung zugeschickt.

Grimm Audio suppose que le lecteur comprend parfaitement le texte en Anglais ci-dessous. En cas de doute s.v.p. contacter Grimm Audio. Si nécessaire, on pourra vous envoyer une traduction.

Grimm Audio da por supuesto que el texto en versión Inglesa no ofrece ninguna duda de interpretación y se entiende íntegramente. Si este no fuese su caso rogamos contacte con Grimm Audio quien, a petición, se encargaría de enviarle la correspondiente traducción.

Please follow these precautions when using this product:

1. Read these instructions.
2. Keep these instructions.
3. Heed all warnings.
4. Follow all instructions.
5. Dangerous voltage is inside this apparatus. Opening is only allowed by qualified service personnel.
6. Verify line voltage before use.
7. Do not defeat the safety purpose of the polarized or grounding-type plug. A polarized plug has two blades with one wider than the other. A grounding-type plug has two blades and a third grounding prong. The wide blade or the third prong are provided for your safety. When the provided plug does not fit into your outlet, consult an electrician for replacement of the obsolete outlet.
8. Protect the power cord from being walked on or pinched, particularly at plugs, convenience receptacles, and the point where they exit from the apparatus.
9. Unplug this apparatus during lightning storms or when unused for long periods of time.

10. Do not use this apparatus near water.
11. Do not use this apparatus outside.
12. Do not expose the apparatus to dripping or splashing. Do not place objects filled with liquids (flower vases, drink cans, coffee cups, etc) on the apparatus.
13. Clean only with a dry, soft, non-fluffy cloth. Do not spray any liquid cleaner onto the cabinet, as this may lead to dangerous shocks. Do not spray any liquid cleaner onto the faceplate, as this may damage the front panel.
14. Install in accordance with the manufacturer's instructions.
15. Do not install near any heat sources such as radiators, heat registers, stoves, or other apparatus (including amplifiers) that produce heat. Avoid exposure to direct sunlight.
16. Use only attachments or accessories specified by the manufacturer.
17. Use only with a cart, stand, bracket, or table designed for use with professional audio or music equipment. In any installation, make sure that injury or damage will not result from cables pulling on the apparatus and its mounting. If a cart is used, use precaution when moving the cart/apparatus combination to avoid injury from tip-over.
18. This unit runs slightly warm when operated normally. Operate in a normal ventilated area. If this product will be installed in a rack, make certain there is sufficient air movement within the rack.
19. Refer all servicing to qualified service personnel. Servicing is required when the apparatus has been damaged in any way, such as when the power-supply cord or plug is damaged, liquid has been spilled or objects have fallen into the apparatus, the apparatus has been exposed to rain or moisture, does not operate normally, or has been dropped.
20. **WARNING:** To reduce the risk of fire or electric shock, do not expose this apparatus to rain or moisture.

1. Installing

Unpacking and Inspection

Your CC1 was carefully packed at the factory and the carton it came in was designed to protect it from the trials and tribulations of shipping. Keep the box and all packing materials, so that in the unlikely event that you need to return the CC1 for servicing, you can do so safely.

Mounting the CC1

The CC1 can mount in any standard 19" rack. The CC1 does not produce RF fields nor is susceptible to them. You can position it near other digital gear such as computer and disk recorders without worry. In general it is a good idea to keep some distance between monitors (LCD and CRT) and audio and word clock cables because of risk of induced low level noise due to stray magnetic fields.

Grimm Audio products have a real wood face plate that provides a beautiful and vivid appearance. To maintain the outstanding looks, one is advised to take some precautions:

- Do not place the CC1 in humid nor very dry environments. The wood might crack.
- Do not use chemical or alcohol based cleaner on the wood.

AC Power Hookup

The CC1 has a linear power supply that needs to be factory set for your local line voltage. Make sure to check the noted line voltage on the back below the IEC cable entrance ('wired for ... V') and verify that this complies with your locally supplied line voltage. Grimm Audio cannot be responsible for problems caused by using the CC1 with improper AC wiring or voltage. Since the CC1 does not have a power switch on the front panel, a convenient way to power down the unit is to use a power strip equipped with a switch.

2. Signal Connections



- Toggles Master 44.1 / 48 kHz and Slave
- Toggles group 1 sample rate multiplication factor
- Toggles group 2 sample rate multiplication factor

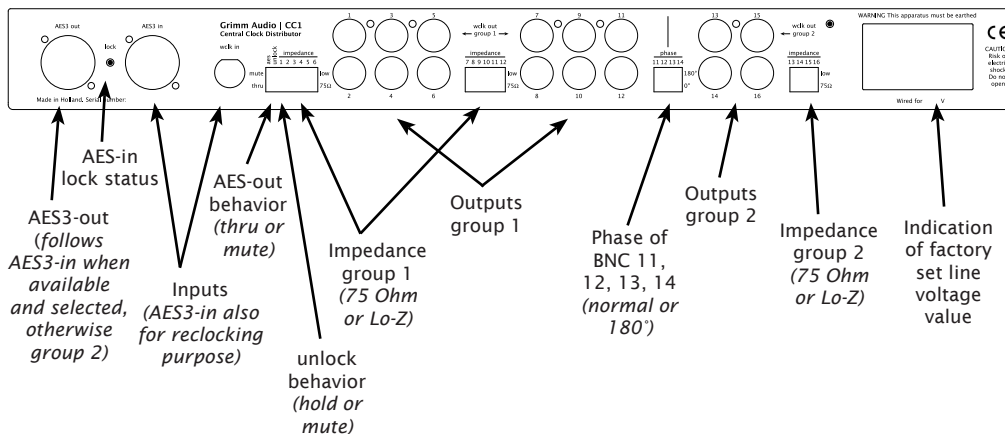

3. Operation

Master mode

The leftmost front panel pushbutton selects between two base clock rates: 44.1kHz or 48kHz. The two other pushbuttons determine the actual clock frequency transmitted across the 16 BNC outputs. They control in two groups. Group 1 are channels 1-12. The second pushbutton sets the multiplication factor for this group to 1x, 2x or 4x. Group 2 are channels 13-16, and their multiplication factor is set by the third pushbutton. Setting “48kHz” using the leftmost pushbutton, “1x” on the middle selector and “2x” on the rightmost selector will set the clock rate on group 1 BNC’s to 48kHz and on group 2 BNC’s to 96kHz.

The AES3 output has two functions, depending on the setting of the dip switch marked “aes” on the rear. It determines whether the audio content found at the AES3 input is passed through to the output (“thru”) or not (“mute”). In “mute” mode the AES3 data will be black and run at the rate selected for group 2. In “thru” mode, the AES3 output will obviously run at the same rate as the AES3 input. On loss of input signal, the output will remain at the same sampling rate.

The exact behaviour of the AES3 output in master mode depends on the use case:

1. No signal connected to the AES3 input. The AES3 output is a black signal (no audio) with the same sampling rate as the Group 2 BNC outputs. The channel status bits indicate “Grade 1 reference” if the CC1 has gone through the optional frequency calibration, otherwise “Grade 2 reference”. The AES lock indicator on the rear is off.

2. A signal is applied to the AES3 input that is not synchronous to the CC1. The AES3 output is a black signal with the same sampling rate as the Group 2 BNC outputs. The AES lock indicator on the rear blinks.

3. A signal is applied to the AES3 input that is synchronous to the CC1, but the “aes” dip switch is set to “mute”. The AES3 output will still be black and synchronous. The presence of the aes signal has no effect. In “master” mode with the “aes” dip switch set to “mute”, any signal at the AES3 input is basically ignored, except that the “aes lock” light on the rear will be on to indicate the presence of a synchronous input.

4. A signal is applied to the AES3 input that is synchronous to the CC1, and the “aes” dip switch is set to “thru”. The AES3 output fully copies audio and subcode data (but not the jitter!) from the AES3 input. In this mode the AES3 output will never indicate “grade 1” as AES11 requires a black signal. The “aes lock” light is on.

5. If the input signal is lost from case 4, the sampling frequency setting is retained, as sudden loss of signal is most likely accidental. This is different from case 1 where an AES3 input signal was never present. If the removal of the AES3 input was on purpose, changing the group 2 multiple on the front will return to case 1, and the AES3 output will once again be synchronous to the selected multiple of group 2.

Slave mode

Slave mode is the third setting on the leftmost selector. In slave mode, the CC1 will look at the word sync input as well as the AES3 input for a valid signal. Slave mode permits the following use cases:

1. Word sync only. Upon selection of slave mode, the CC1 selects the word sync input. The middle and right selector once again set groups 1 and 2 to a multiple of the base rate. The AES3 output will be black, synchronised to group 2 and the chan-

nel status marked “no reference”. Upon loss of lock, the output frequency will be held constant, see case 4.

2. AES3 only. Upon selection of slave mode, the CC1 selects the AES3 input. The “aes” dip switch at the rear selects whether the audio data is transmitted (thru) or not (mute). In thru mode, the AES3 output will obviously run at the same multiple as the AES3 input. In mute mode it will be synchronous to group 2, audio is black and marked “no reference”. Upon loss of lock the output rate will be held constant, see case 4. The “AES lock” light on the rear will be on as long as the CC1 PLL is locked.

3. Both AES3 and word sync are present. Word sync will take precedence over the AES3 input. In “thru” mode the AES3 output will produce a jitter-free copy of the AES3 input, provided the input signal is synchronous. In “mute” mode the AES3 input will be ignored altogether. Upon loss of the AES3 input the AES3 output will revert to black. Upon loss of the word sync input the output frequency will be held constant (within 1 ppm of the last detected frequency) and the front slave light will blink to indicate an error. The fault condition is cleared either by reattaching the word sync or by cycling the source selector through the two master modes back to slave mode to force the CC1 to lock to the AES3 signal instead. The CC1 will never automatically switch from word sync to AES3 to prevent clock loops.

4. No valid signal on either word sync or AES3 input. The response is now determined by the dip switch named “unlock”. When set to “thru”, the clock frequency will be held constant within 1 ppm of the last valid measured frequency. When set to “mute”, the outputs will be muted. In both cases the slave light will blink to indicate an error. The “mute” mode is advantageous at for instance post production where the clock usually is out of sight in a machine room. Upon loss of lock, all clocks disappear and your software automatically provides a warning. The “thru” mode has an advantage in for instance live recording or Public Address. Here sound should never mute, whatever happens.

Lock indication

The CC1 detects whether the input signal is a multiple of 44.1kHz or 48kHz, and indicates this on the LEDs above the source pushbutton. The frequency multiple settings of groups 1 and 2 remain as set by the user. While the CC1 acquires lock, the slave light will blink. This can take up to 20s, on account of the CC1’s extremely slow PLL design (see chapter 6, “Jitter and PLL’s explained”). Once frequency lock is achieved, the slave LED will come on continuously. The PLL will then settle to 0° phase lock with the input in an even slower mode. The smallest achievable phase error depends mostly on the stability of the incoming clock. The static (average) phase error is factory-aligned to within 50ns.

The “lock” LED on the rear indicates the AES3 receiver status:

1. Off: No AES3 signal present.
2. On: AES3 signal present and found to be synchronous with the CC1.
3. Blinking: An AES3 signal is present but it is out of sync with the CC1.

Impedance

The “impedance” DIP switches on the rear allow each individual output to be set to low-impedance (25 ohms typical) or characteristic (75 ohms) impedance. The switches are factory set to 75 ohms. Should the receiving device have problems recognising the word sync signal, you might try the low impedance setting.

Word sync connections are usually 5V square waves transmitted over 75 ohm (video) coax cables. Although the word clock frequency itself is relatively low, the transitions are steep. Taken as a whole, word sync is a wideband signal, necessitating characteristic termination at least at one end of the cable. Single-terminated lines are usually terminated on the source end. Better still is series termination on the transmit end and parallel termination on the receiving end. This minimises reflections even when the cable impedance is not exact. Double termination like this produces a 6dB loss, resulting in a 2.5V signal. All Grimm Audio products are designed to work in this manner.

There is no standard defining word sync connections. As a result, implementations vary across makes. Outputs may be series terminated or low impedance, DC or AC coupled. Inputs may be parallel terminated or high impedance. This yields 8 permutations, all of them encountered in the wild. The CC1 input will correctly interpret all variants without user manipulation, but the impedance of the CC1’s outputs may need to be set low in some cases. A parallel-terminated input expecting a 4V input signal will only work with the CC1’s output impedance set low. A fair number of products were found to have parallel terminated input but stop working around 2.5V which is why the CC1 puts out a slightly higher-than-normal voltage in order to allow correct operation in the factory preset mode. Nevertheless, some equipment will only respond correctly when the output impedance DIP switch is set to low.

Phase

Channels 11 to 14 can be polarity-reversed (180° phase shift) to cater for equipment that uses the falling edge to synchronise on instead of the rising edge. Should you encounter operational problems with equipment, even though it is locked, check the manual for any mention of clock phase and try the 180° switch setting.

AES and unlock switches

The 'aes' and 'unlock' switches can be set to 'mute' or 'thru'. The behavior of the CC1 in these modes is described in Chapters 'Master mode' and 'Slave mode'.

Key Lock mode

If your CC1 is used in one setting most of the time you can use "Key Lock" mode to prevent clocking errors by accidental pressing of control buttons on the CC1's front panel. In this mode the CC1 does not respond to the push of any button. "Key Lock" mode is engaged by holding the "44.1/48/Slave" button during power up. It will then lock the mode that was set before the last power down. To leave "Key Lock" mode, hold the "44.1/48/Slave" button during power up again.

4. Setting up the Studio

In a digital studio all equipment will need to be synchronised. If all there is are two boxes, one sending and one transmitting, all that is needed is a digital signal and the recipient will lock to that. When multiple sources are feeding into one recipient (e.g. a digital desk connected to several digital recorders and converters), all sources will need to be synchronous. This is what a house sync (aka master clock) is for. Several formats are in use. The AES promotes a standard called AES11 that uses an AES3 link, but most equipment tends to use a word sync signal on a BNC connector. The AES11 standard is to be amended to include this practice. We think this is a good move, since the purity of a clock recovered from an AES3 link is rather susceptible to issues like cable length and bandwidth limitations. The AES3 output on the CC1 is provided to cater for the few equipment that needs AES11 over AES3. When the output is not used for this purpose, it doubles as a jitter removal function for any AES3 signal (provided it is synchronous with the CC1).

Most studios that have introduced a house sync have noticed a change in the overall sound quality of their equipment. Usually for the better, sometimes for the worse. At issue is jitter (akin to wow and flutter, but then applied to the sampling clock). Chapter 6 "Jitter explained" will go into more details. The important point to remember is that jitter affects audio quality only at points in the chain where an actual time-based conversion is taking place, typically AD and DA converters but also increasingly asynchronous sampling rate converters.

Connection

The CC1 will usually be located in the machine room. Each device connected to the CC1 is set to “slave to word sync”. The best connection scheme is “star distribution” with each output of the CC1 connected to one device. The sixteen outputs will normally suffice. Daisy chain connections are best avoided, as are T-junction connections. The latter will most likely fail anyway because of the lack of standardisation of termination impedance and signal level, not to mention mechanical failure of T-junctions themselves.

Try to prevent circulating ground currents through the coax cables (ground loops). As coax cables go, they are unbalanced and currents flowing through the cable shields will impose an error voltage on the signal, causing jitter at the receiving end that wasn't there at the transmitting end. One common cause of circulating currents is leakage current through the power supply of an ungrounded product. Another is voltage drop between the earth ground connection between devices that are located far apart. Minimizing the loop area encircled by the entire loop, comprising the word sync cable and the mains cords is usually a good idea. By all means, never defeat the safety earth connection of any device that is designed to have an earth connection. Lifting grounds may produce a lethal shock hazard.

The CC1 itself has a low-impedance reference plane at the rear, insuring that it will never be affected by circulating currents. Not all equipment is designed in this manner. In case your system holds interfacing equipment that is sensitive to ground loops, Grimm Audio has an isolation transformer available on demand (CI1). Such devices degrade clock quality somewhat so they should be avoided when driving equipment of which the AD/DA section is used. When a current loop involving several pieces of gear needs to be broken, it is best to install the CI1 in lines feeding non-performance-critical equipment such as digital I/O sound cards, and to use normal, direct connections between the CC1 and any AD/DA converting equipment.

AES3 reclocking

Apart from the word sync input and sixteen outputs, the CC1 also sports an AES3 input and output. The output can carry an AES11 DARS signal but it may also be used to transmit a re-clocked (de-jittered) copy of the signal at the AES3 input. This may be useful when driving a jitter sensitive device lacking a word sync input, most typically an outboard DAC in the monitoring system or a digital loudspeaker.

The reclocking function is available in all configurations, that is, master, slaved to word sync or slaved to the AES3 input itself. Apart from the latter trivial case this implies that the source of the AES3 signal should itself be somehow synchronised to the CC1. Setting the “aes” switch to “thru” activates the reclocking mode, passing maximally jitter-free signal to e.g. a DAC. In most cases this will improve replay quality significantly.

In consumer use, most equipment features RCA S/PDIF connectors in stead of XLR AES3 connectors. To facilitate Hi-Fi use of the CC1, all our consumer units are shipped with an S/PDIF <-> AES3 conversion cable set.

Clock Loop

A clock loop is a runaway situation where two devices are slaved to eachother, for instance the CC1 slaved to a recorder which in turn is slaved to the CC1. Neither device is the clock master and the result will usually be that the clock frequency ends up at an extreme of the tuning range of one of the devices. Before setting the CC1 to slave, insure that the clock input originates from a master.

PLL setting in attached devices.

Audio devices capable of locking to an external clock use a phase-locked loop to do so. Details of this are covered in our white paper “PLL and clock basics” that can be found on the info page of our website. An important thing to know for a CC1 user is that some products have two modes, usually called “fast/wide” or “slow”. The slow setting has the best suppression of incoming jitter, and is the optimum choice when the incoming clock is polluted. The downside of the slow setting is that the jitter in the recovered clock is fully dominated by the clock oscillator that forms part of its PLL. If the incoming clock happens to be much stabler than that, the slow mode will actually end up adding jitter. The latter scenario is almost guaranteed to be the case with the CC1, which is significantly cleaner than any clock oscillator we’ve found in commercially available audio products so far. As a rule, in this case it is usually better to select the “fast” mode. In fast mode, the PLL will track the incoming clock more closely and if the incoming clock is extremely clean, the same will go for the regenerated clock.

Products that have a fixed slow PLL, such as those from Apogee, dCS, Lynx or Prism Sound, will improve comparably little compared to products with a switchable or relatively fast PLL like those from Avid, Lavry Engineering, MOTU, Mytec, SSL or RME. Digital loudspeakers that feature a word clock input, like Dynaudio Air, will also benefit from slaving to the CC1.

Syncing to Video

Before complicated digital studios became practical, video studios have been using house syncs for decades. As soon as more than one camera is used, all sources need to be synchronised. Apart from a time base reference there is also a need to know the actual timing of a frame. This information is provided by time codes. Although the time code signal is of course synchronous with the video sync, it is usually transmitted separately. In some cases the “LTC” code is used as main video

sync, but fortunately it is going out of fashion. LTC is probably the least stable time reference around.

Enter digital audio. The audio track now needs to be synchronised to the picture. Word sync has a better time resolution than video sync, but still the most common practice is locking the audio clock to the video clock. Even modern digital video production practice tends to lock audio to an analogue video signal. This is unfortunate because low jitter is not exactly a design spec for a video sync generator.

The CC1 cannot slave to video sync directly. In order to avoid direct crosstalk between the black-burst generator or receiver and the audio clock, we have omitted video sync functionality. Our best advise is to use the CC1 as the audio master and slave all video to the audio word sync. If you nevertheless do need to slave the audio system to video sync you can either buy our VCC 'Video to Word Clock' converter or use any other generic video to word clock converter. Connect the retrieved word clock to the CC1's word clock input and have the CC1 clean up the sync and distribute clock to the audio devices as usual. The extraordinary stability of the CC1's PLL will make sure the result comes as close as possible to making the audio chain master.

Hints

- Select decent quality 75 Ohm coax cables and certainly do not skimp on the quality of the connectors.
- Make cables no longer than necessary.
- Cables add propagation delay. It is exceedingly rare for differences in clock phase to affect the interoperability of connected audio equipment, but if it happens, using equal length cables throughout helps.
- Disconnect unused gear.
- Ideally do not leave the word clock input connected when the CC1 is master. Although unlikely (the CC1 has a relay to actively disconnect the input when not in use), there is a possibility of cross-talk from the input clock to the outputs. Likewise, do not leave an AES3 cable attached if not needed.

5. Pro Tools

Avid Pro Tools is by far the most common DAW, warranting a special section on how to set up the CC1 in a PT rig. In our experience described method is the set-up that leads to the best sound quality. Any deviation from this method might give you stable sync, but will probably not be sonically optimal.

Pro Tools in music production, CC1 master

Pro Tools 192 interfaces feature a “Loop Sync” function where clock cables are connected in a ring: every “Loop Sync in” is connected to the next unit’s “Loop Sync out”, the last unit connects to the first. Like in any correct clock setup, one unit is master and all others slave. The advantage of Loop Sync is any unit can be designated master and run on its internal clock. All others slave to that unit. The Loop Sync input of the master unit is ignored and effectively an ordinary word clock daisy chain results. Now if Pro Tools is to slave to word clock, the unit that receives the word clock always becomes loop master, the others automatically slave to Loop Sync. We can make use of this feature by fooling the system into believe that Loop Sync is in use, while actually a star clock distribution is utilized. Star clock distribution has the advantage that it is more fail safe than daisy chaining and jitter gain of subsequent PLL’s is avoided.

- Connect an output of CC1’s group 2 to the “External Word Clock” input of the first unit in the chain (if present the Sync I/O, otherwise the first 192).
- Connect the outputs of CC1’s group 1 to the Loop Sync input of each “192” interface. Every 192 gets its own connection to the CC1 (star distribution). Make sure group 1 is set to ‘x1’.

In case you need to run higher sample rates than 44.1 or 48 kHz, only set group 2 on the CC1 front panel to “x2” or “x4” and leave group 1 on “x1”. This because Pro Tools “External Word Clock” input needs to receive the actual sample rate, but the Loop Sync inputs always run at the base rate.

- Software settings:

Setup – session setup

1. Set Sync source to “Word Clock”. This configures the first unit to lock to external word clock and the others to loop sync (indicators light up).

Pro Tools in music production, CC1 slave

An alternative setup when using a Sync I/O as first unit in the chain is to assign the Sync I/O master and slave the CC1 to its Loop Sync output. The advantage is that

the whole system will automatically track the project's sample rate. Disadvantage is that in theory jitter on the CC1's outputs will be slightly higher. The CC1's jitter attenuation however is so large we do not expect this to be a problem.

- Connect the Loop Sync output of the Sync I/O (which is first unit in the chain) to the word clock input of the CC1. Put CC1 in slave mode.
- Connect the outputs of CC1's group 1 and/or group 2 to the Loop Sync input of each "192" interface. Every 192 gets its own connection to the CC1 (star distribution). Make sure group 1 and 2 are set to 'x1'.
- Software settings:

Setup – session setup

1. Set Sync source of the Sync I/O to "Master". All 192 interface will automatically switch to Loop Sync, which is taken care of by the CC1.

Pro Tools in post pro.

Here you'll need to sync to video and time code. As outlined above, set the video equipment to lock to word sync or use a video sync generator that accepts a word sync input from the CC1. Naturally the ProTools hardware is receiving word clock directly from the CC1. Also connect video sync to the Sync HD, it will be used just for time code synchronisation.

The word clock connections are as described in the former paragraphs "Pro Tools in music production". Special attention is needed for the time code connection. Up till Pro Tools 8 there was no way of combining the Sony P2 "Machine Control" time code signal with an external word sync like the CC1. Selecting Sony P2 forced the Sync I/O to slave to video sync. With current versions of Pro Tools you can lock to word clock while at the same time using the video ref input on the Sync HD for frame edge alignment of P2 sync. However, this only works for PAL and NTSC, not for hi def rates. It is hoped that a future software update will address this. In the mean time, for hi def production, please use the following workaround.

Since there is no such issue with LTC, we get to use three connections to the Sync HD: word clock, LTC and Sony P2 for pure machine control. For clocking, have ProTools slave to word clock as described in this manual. In this case do not connect video sync to the Sync HD. This insures that, if you happen to accidentally switch to the video sync input, you get a clear error message to alert you to the problem. For time code and machine control, follow the next steps:

- Software settings (take care to execute the following steps in the order described):

Setup – Peripherals

1. On the “Synchronisation” tab: select device “Sync HD” and port “any” (the LTC input will be automatically selected)

2. On the “Machine Control” tab: tick “9 pins serial” (Sony P2). Untick “use serial time code for positional reference”. Leaving this option ticked causes the Sync HD to try syncing to video sync instead of word sync. An additional disadvantage of Sony P2 is that it does not sport a “continuous resync” like LTC, signalling time code only together with transport commands.

Setup – Session setup

3. Set Sync Source to “Word Clock” (the previous step will have automatically selected video sync instead, hence the need for executing the steps in order). The Loop Sync indicators will light up.

Controlling the external machine can be done in two ways:

a. The transport buttons on Pro Tools control the machine via the Sony P2 interface. The machine generates LTC. Pro Tools is slaved through the Sync I/O’s LTC input or any other LTC to MTC converter connected to your computer. Lock is achieved within one second. This is the preferred method.

b. Pro Tools is controlled directly by its transport buttons. The external machine locates and gets into play through Sony P2 locator commands. The user selects a cue point and hits play. The external machine will rewind to this time code minus a pre-roll and starts rolling. Pro Tools waits until it sees the correct time code coming back (Pro Tools slaves to the LTC of the machine). A potential problem occurs when the external machine fails to achieve sync during the pre-roll period. When everything is slaved to word sync there is little chance of such a thing happening and one second of pre-roll should suffice. While playing, Pro Tools will run in trigger sync mode. That is, once it’s started playing it will ignore positional information, verifying only that time code is still running. This method may for instance be selected when using hard disk video players.

6. Jitter and PLL’s explained

Jitter is an instability in the timing of a clock signal. Ideally the rising or falling edges of a clock signal are all separated by exactly the same amount of time. In reality, the timing is more uncertain. The graph below shows the time-domain view of the problem.

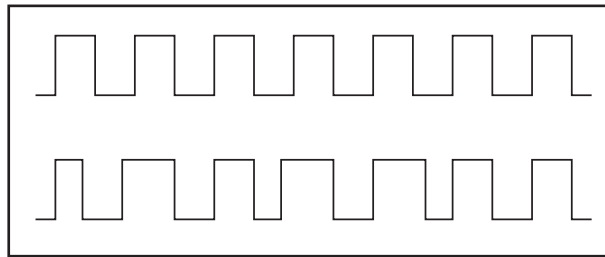

A stable and a jittery clock signal

We can also look at the problem spectrally. An ideal clock has only a single frequency components (and harmonics). All energy is concentrated on an infinitely narrow frequency band, see the top picture below. When jitter is present, side bands occur. Some spectral energy is located away from the clock. The faster the timing chatters, the further away from the main frequency you'll find energy.

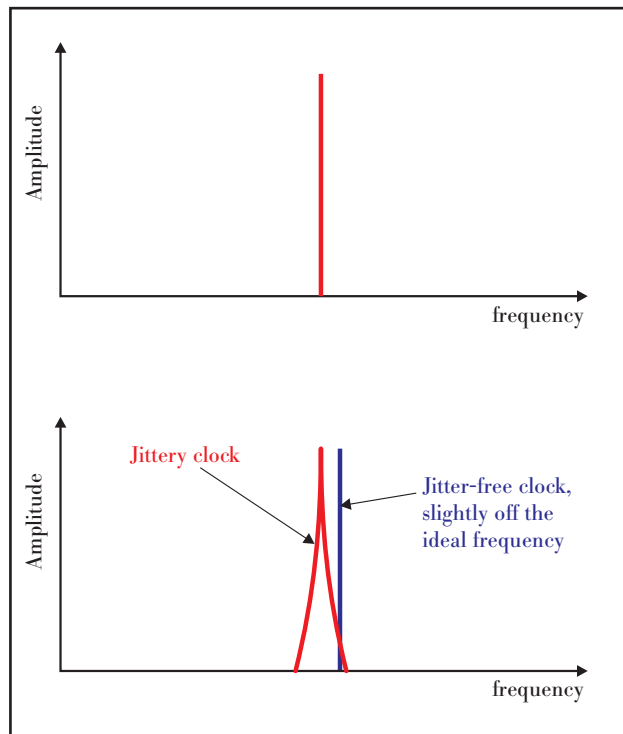

Spectra of clock signals

The red curve in the bottom graph shows only random jitter. Sometimes jitter is periodical and then you wouldn't see a smooth slope but sharp peaks. An important note is that frequency accuracy has absolutely nothing to do with jitter at all. The red graph shows a jittery clock with an exactly correct frequency, say 44100.0000000Hz, the blue one shows a clock that's somewhat off but otherwise brilliantly stable. A frequency error can be annoying from a practical perspective,

but as far as signal quality is concerned you're better off with a stable clock at an inexact frequency.

Jitter is not a problem in fully digital processes. As long as it isn't so large that a processor can't distinguish the previous bit from the next, all-digital processes are completely indifferent about jitter. The problem occurs when you go from the analogue domain into the digital domain or back. Digital audio presumes uniform sampling. That way, given a string of numbers and knowledge of the sampling interval, you can perfectly reconstruct a sampled signal. With jitter that theory falls flat on its back.

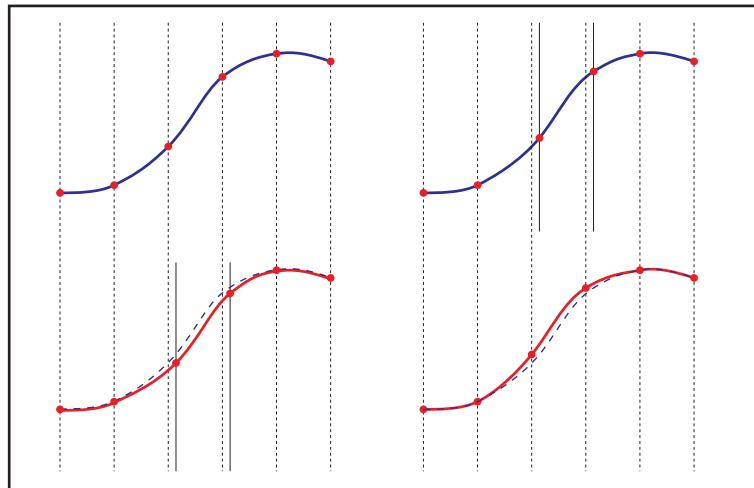

Jitter in AD (top) and DA (bottom) converters

Imagine the signal on top. The AD converter samples it at neatly uniform intervals. The DA converter reconstructs the correct values but it gets the timing wrong. The difference between the red and blue curve shows the error. Or take the converse: the DAC is fine but the ADC took samples at the wrong time. The effect is much the same. What's worse in this case is that the numbers we've recorded are now wrong. In the previous case we could slap in a better DAC, with a jittery ADC the game is over.

PLL's

Converter chips need a high frequency clock signal, usually something around 22MHz. It is always made by a local oscillator (anything from a simple RC oscillator in a receiver chip to a crystal oscillator) regardless of whether the unit is operating in master or slave mode. This local oscillator is indispensable: external sync signals may be AES/EBU, a sample rate frequency "word clock" or even a video signal, neither of which are of any direct use to the AD/DA. Instead, the local oscillator is sped up or slowed down to make it run in step with ("locked to") the sync signal. A system that uses a local oscillator "pulled" in sync with an external signal is called a Phase Locked Loop (PLL). A "phase detector" compares the local clock with the

external sync signal and puts out a signal when the local oscillator runs too fast or too slow.

Now, the PLL will track the external sync closely, but not too closely. Unwanted fluctuations (jitter) of the external sync signal are to be ignored but if the local oscillator drifts off it should be pulled back into step. So how does the PLL tell the difference? It can't. It sees only the difference between the two clocks. All it can do is ignore short term differences (high-frequency jitter), whilst tracking slower fluctuations (low-frequency jitter). After all, a slow change could be due to drifting of either the external sync signal or the local oscillator. Either way, the PLL must get the local oscillator to follow the sync at long last, lest lock be lost.

The cut-off point between "slow" errors and "fast" errors (known as the "PLL bandwidth") is chosen by the designer, based on an assumption of how stable the local oscillator is compared to the external sync signal. Above the cut-off point, the PLL will not reproduce any errors present in the input, but neither will it be able to correct errors committed by its own local oscillator.

Here's the transfer of a basic PLL, designed to have a cut-off frequency of 4kHz.

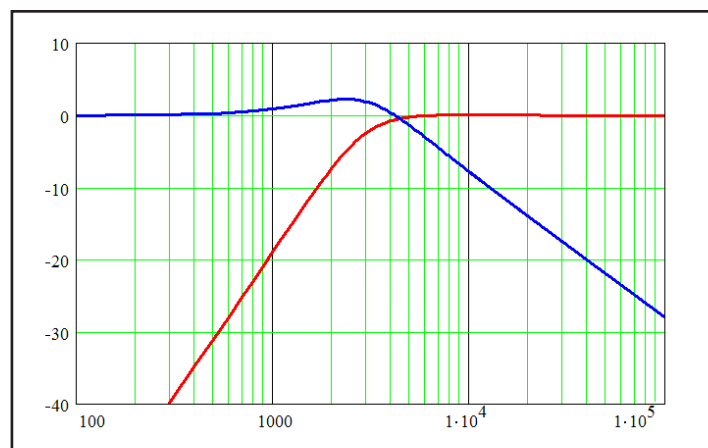

Attenuation of input (blue) and local (red) jitter by a PLL

Mark that in this graph we are not looking at audio frequencies, but at jitter (or 'fluctuation') frequencies. The blue curve shows the attenuation of input jitter. The red curve shows the attenuation of the local oscillator's jitter. Below the cut-off frequency the external oscillators jitter dominates, above cut-off the local oscillators'. A cut-off frequency at 4 kHz or higher can be found in AES/EBU receivers and general word clock inputs. If he regards the quality of his local clock highly, the designer of a PLL can decide to put the cut-off point much lower, for instance at 10 Hz or even further down. This makes for a 'slow' PLL with a very narrow bandwidth.

A quick way of seeing if a PLL is slow or fast is to see how long it takes to achieve lock. Usually, slow PLL's also take a while to lock. The CC1 takes about 40 seconds

to lock and has a 0.1Hz bandwidth. Typical AES/EBU receiver chips lock within a few samples and have a bandwidth of around 10kHz.

If the local clock is very clean, a narrowband PLL is the best choice because all but the lowest-frequency jitter in the external sync is rejected. A converter designed along those lines will sound stellar under all conditions. If the external sync is very clean, a wideband PLL is the best choice because the local oscillator's own errors will be corrected. This is the case where a good external sync like the CC1 improves a budget converter, or even a pricey one, beyond expectations.

If the designer guesses wrong however, a too- fast PLL might end up forcing an otherwise fine local oscillator to reproduce faithfully every bump and hiccup in the external sync signal. Equipment constructed along these lines sound good in master mode but will only improve in slave mode if the external sync is stabler than the internal oscillator. An unstable external sync actually makes it sound worse.

Alternatively a too-slow PLL might not correct a local oscillator of suboptimal quality. In that case, jitter performance is bad regardless of the quality of the external clock. And here lies the rub: a slow PLL will always make a converter sound the same, but not necessarily good. If a converter is insensitive to external jitter, that alone is no indication that its internal jitter is low. A slow PLL shuts the door to external jitter, but also to any improvement to be had from external clocking with a very stable source.

In short, one cannot expect an external clock to work miracles everytime. If the PLL of the receiving device is slow, the sound quality will be independent of the quality of the external clock, for better or for worse. If the PLL is fast, real improvements can be had.

By example, the graph below shows the result of measurements on a well known DAW converter. The jitter performance, measured at the converter chips' clock pin, improves substantially at jitter frequencies below 200 Hz when slaved to a CC1.

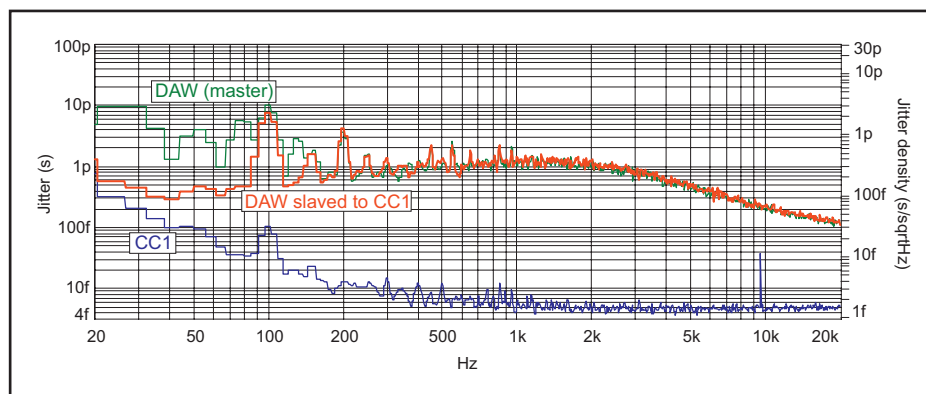

Jitter performance of a well known DAW converter

7. Specifications

The clock PLL is a hybrid analog / digital design, based on a discrete design ultra-low jitter crystal oscillator. In master mode the oscillator is temperature compensated. Local shunt regulators featuring 120 dB power supply rejection and a high impedance supply path, thus all variations in load current are kept local to the circuit: the power buss and ground carry only DC current.

Specifications

Word clock input impedance 75 Ohm.

Word clock input sensitivity better than 1Vpp.

Word clock output impedance 75 Ohm or 25 Ohm ('low') on selected channels.

Word clock output voltage, terminated 2.7 Vpp, unterminated 5.5 Vpp. DC coupled.

Latency word clock in - word clock out: adjusted to less than 50 ns, but may be larger due to input clock jitter.

Internal intrinsic clock jitter 2,1 ps RMS (above 10 Hz).

Clock frequency master mode: 1, 2 or 4 times 44.1 or 48 kHz \pm 10 PPM, 5 - 50 °C.

PLL performance (slave mode):

90 dB attenuation @ 10 Hz, improving at 60 dB/dec above that.

Pullability of clock frequency: \pm 50 PPM (conform AES11 Grade 2).

Maximum ambient temperature for operation: 50 °C.

Life expectancy power supply electrolytics > 45.000 hours.

Power supply voltage range +/- 20%

Fuses:

120V (USA): fuse 500mA

100V (Japan): fuse 500mA

230V (EU): fuse 250mA

Weight: 4 kg

Dimensions: 430 x 200 x 44 mm.

Power consumption: 15 W.

Wood type of front: Abachi.

Grimm Audio contact information

Grimm Audio CV
Strijpsestraat 94
5616 GS Eindhoven
The Netherlands
+31 (0)40-213 1562

Email: info@grimmaudio.com
Website: <http://www.grimmaudio.com>

8. Grimm Audio Limited Warranty

Grimm Audio CV (“Grimm Audio”) warrants this product to be free of defects in material and workmanship for a period of one (1) year for parts and for a period of one (1) year for labor from the date of original purchase. This warranty is enforceable only by the original retail purchaser and cannot be transferred or assigned.

During the warranty period Grimm Audio shall, at its sole and absolute option, either repair or replace free of charge any product that proves to be defective on inspection by Grimm Audio or its authorized service representative. In all cases disputes concerning this warranty shall be resolved as prescribed by law. To obtain warranty service, the purchaser must first call or write Grimm Audio at the address and telephone number printed below to obtain instructions where to send the unit for service. All enquiries must be accompanied by a description of the problem. All authorized returns must be sent to Grimm Audio or an authorized Grimm Audio repair facility postage prepaid, insured and properly packaged. Proof of purchase must be presented in the form of a bill of sale or some other positive proof that the product is within the warranty period. Grimm Audio reserves the right to update any unit returned for repair. Grimm Audio reserves the right to change or improve design of the product at any time without prior notice.

This warranty does not cover claims for damage due to abuse, neglect, alteration or attempted repair by unauthorized personnel, and is limited to failures arising during normal use that are due to defects in material or workmanship in the product.

In no event will Grimm Audio be liable for incidental, consequential, indirect or other damages resulting from the breach of any express or implied warranty, including, among other things, damage to property, damage based on inconvenience or on loss of use of the product, and, to the extent permitted by law, damages for personal injury.

© 2011, Grimm Audio CV. All rights reserved
Reproduction in whole or in part is prohibited.
Specifications subject to change without notice.

